



## LEVEL INDICATOR

# MN21

Product Line: **Pressure**

Level sensor activated through the pressure exerted by the material on the membrane.  
Durable construction with aluminum casing.



Solids



Food products

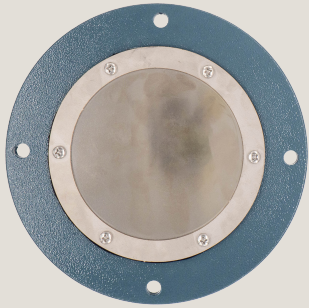

### ADVANTAGES

- An **EASY TO INSTALL** instrument that does not require any calibration, maintenance or specific tool for its installation.
- **ADAPTABLE** to any material, thanks to the adjustable sensitivity, between 10 and 500 mbar.
- Extremely **VERSATILE**, it can be installed in a vertical, horizontal or oblique position.



IECEX - ATEX  
DUST ZONE 20/21



European Union  
Conformity



United Kingdom  
Conformity

### AVAILABLE VERSIONS

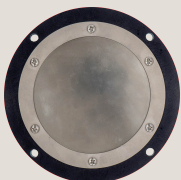

#### MN21F

Version with  
a smaller flange



# LEVEL INDICATOR MN21



Solids



Food products

Product Line: **Pressure**

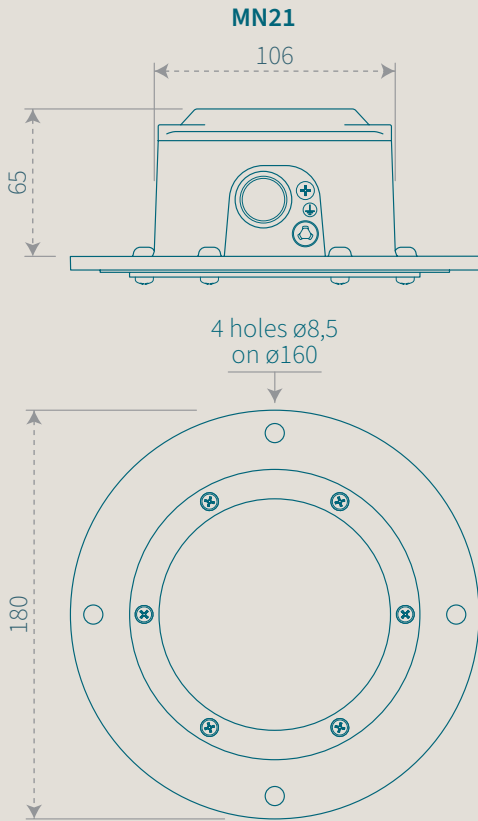

## Customizations



Faston terminals (standard)

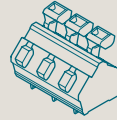

Screw terminal blocks



M12 Circular connector



Lamp

